

# Roto-Cone® Type W

## Dimensions

### Fixed Center Drive

1/4 - 25 HP @ 1750 rpm



## Standard Bores

Model	Standard Bores
RC55W	1/2, 5/8
RC60W	5/8, 3/4
RC75W	5/8, 3/4, 7/8
RC80W	3/4, 7/8, 1, 1-1/8
RC105W	3/4, 7/8, 1-1/8
RC100W	1-1/8, 1-1/4
RC1315W	1-3/8, 1-5/8
RC1330W	1-1/4, 1-5/8, 1-7/8

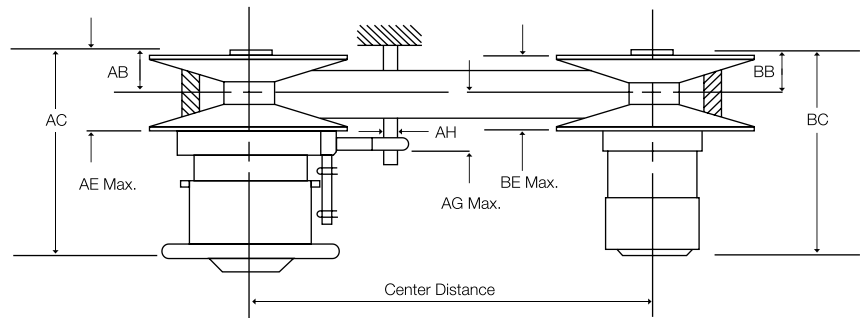
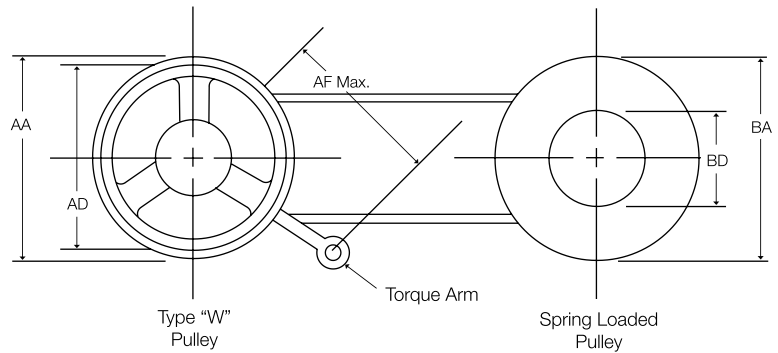

## Roto-Cone Type W Dimensions

Driver Model	Driven Model	AA	AB	AC	AD	AE Max.	AF Max.	AG Max.	AH	BA	BB	BC	BD	BE Max.
RC55W	RC55	5.50	1.00	6.31	5.50	1.81	4.00	1.81	.50	5.50	1.00	4.75	2.06	1.18
RC60W	RC60	6.00	.94	6.75	5.50	2.25	4.00	2.38	.50	6.00	.94	5.75	2.25	2.25
RC75W	RC75	7.50	1.25	8.31	7.50	2.63	6.25	2.13	.63	7.50	1.25	7.13	2.63	2.63
RC80W	RC80	8.00	1.44	9.19	7.50	2.75	6.25	2.88	.63	8.00	1.44	8.00	2.88	2.75
RC105W	RC105	10.63	1.81	9.19	7.50	3.00	6.25	2.19	.63	10.63	1.81	8.00	2.88	3.25
RC100W	RC100	10.00	2.06	11.88	9.00	3.88	6.25	3.69	.63	10.00	2.06	10.19	3.63	3.88
RC1315W	RC1315	13.00	2.25	15.44	12.00	5.38	9.50	5.06	.63	13.00	2.25	12.56	4.50	5.38
RC1330W	RC1330	13.00	2.50	14.25	12.00	5.38	9.50	3.75	.88	13.00	2.50	12.00	6.25	5.63

## Dimensions

### 1/4 - 25 HP @ 1750 rpm

LINE NUMBER	HP RATING @1750	PULLEY MODELS		DRIVEN SPEEDS 1750 RPM DRIVER		CENTER DISTANCE (IN.)								
						1422V BELT								
						360	420	480	540	600	660	720	780	
1	0.25	RC55W	RC55	5000	600	12.45	15.45	18.45	21.45	24.45	27.45	30.45	33.45	
						1922V BELT								
						363	403	426	454	484	544	604	666	726
2	0.5	RC60W	RC60	5000	600	12.05	14.05	15.2	16.6	18.1	21.1	24.1	27.2	30.2
3	1	RC60W	RC75	2700	490	10.79	12.79	13.94	15.34	16.84	19.84	22.84	25.94	28.94
4	1.5	RC75W	RC75	4800	600	10.47	12.47	13.62	15.02	16.52	19.52	22.52	25.62	28.62
						2322V BELT								
						441	481	521	541	601	661	721	801	1001
5	2	RC80W	RC80	4400	600	13.7	15.7	17.7	18.7	21.7	24.7	27.7	31.7	41.7
						2926V BELT								
						574	606	646	686	726	834	906	1006	
6	3	RC105W	RC105	3600	450	18.2	19.8	21.8	23.8	25.8	31.2	34.8	39.8	
7	5	RC100W	RC100	3820	600	18.1	19.7	21.7	23.7	25.7	31.1	34.7	39.7	
						4430V BELT								
						730	790	850	910	970	1030	1090	1150	1320
8	15	RC1315W	RC1315	3000	600	22.7	25.7	28.7	31.7	34.7	37.7	40.7	43.7	52.2

The following charts are based around a 1750 rpm motor. All other motor speeds will be proportional.

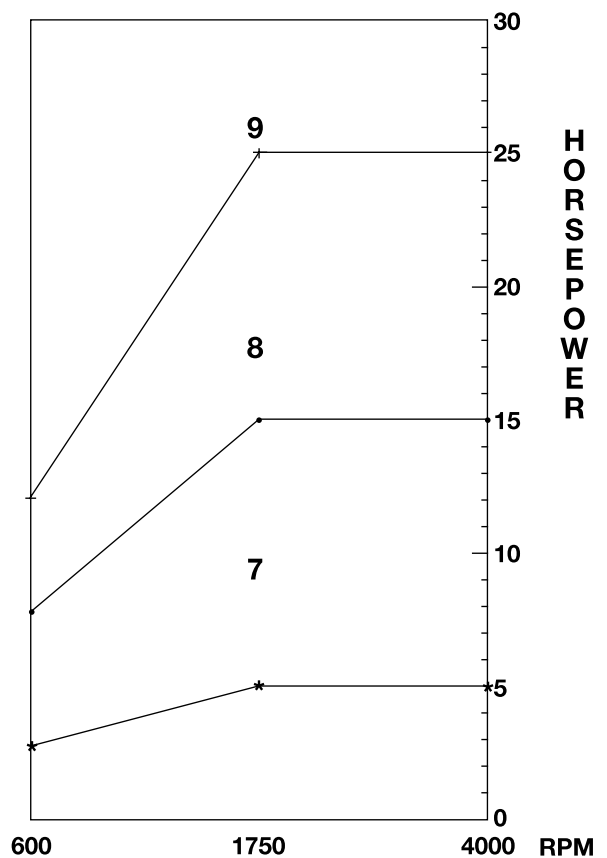
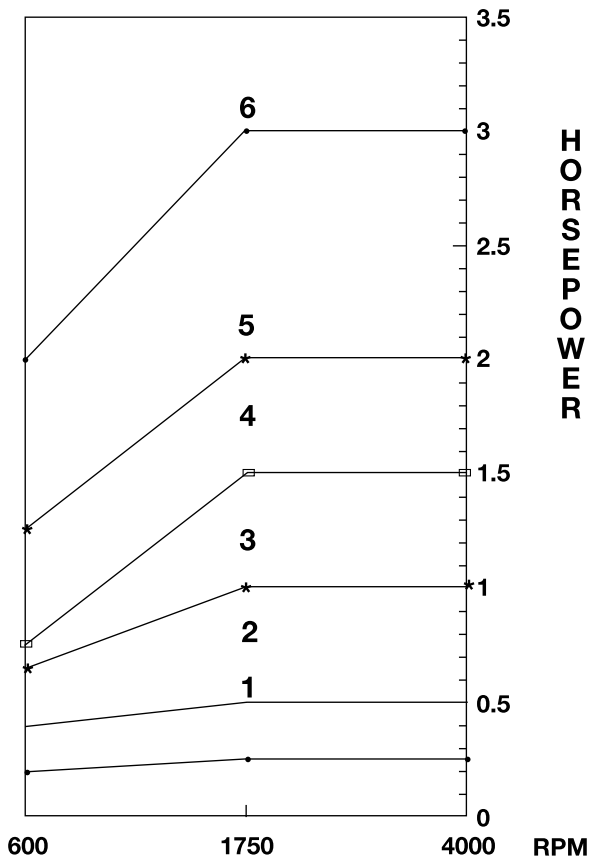

Graphs show horsepower rating for line number indicated.