

9" Pitch Steel Hinge Belting (#9018-4FLHD)

- ✓ 14000 Pound Maximum Belt Pull
 - ✓ 3/16" Thick Pans
 - ✓ 3/8" x 2" Chain Bars
- ✓ 4" Diameter x 1-15/16" Face, Hardened Sintered Steel Rollers
 - ✓ Heat Treated Roller Bushings
 - ✓ 3/4" Diameter C1045 Belt Pins
- ✓ Plain, Perforated, Dimpled Pans Available
 - ✓ Cleats available to suit application

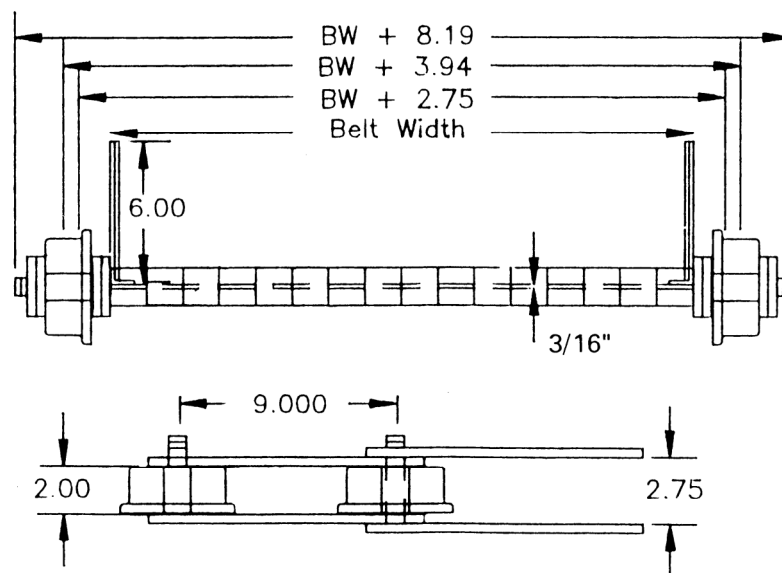
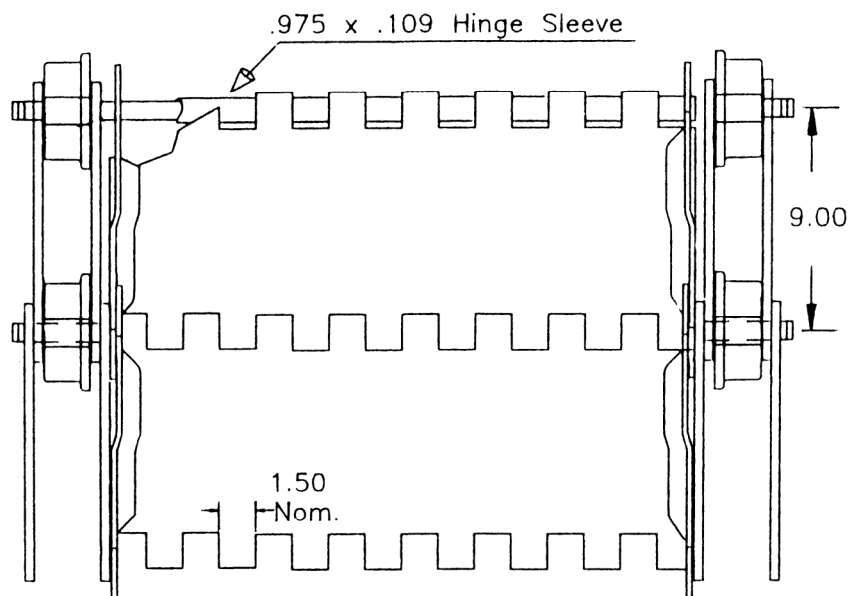

Cleveland, Ohio USA

Phone & Fax: 800-577-0559 Email: sales@davis-ohio.com

Web: www.davis-ohio.com